

1

2

3

4

5

6

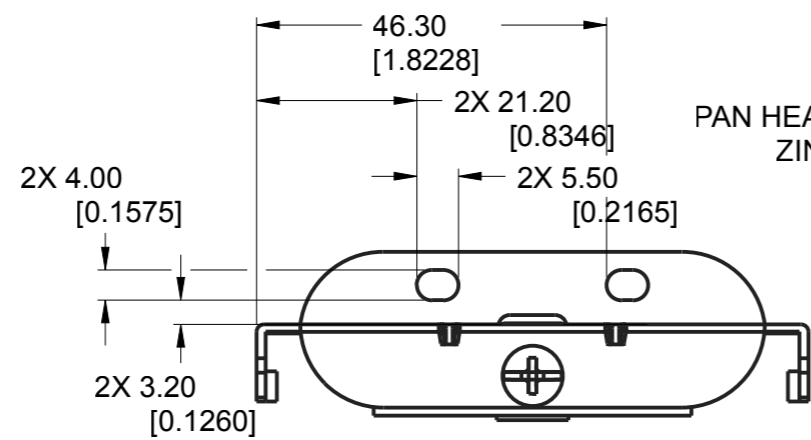

M5 SCREW 25MM LONG
PAN HEAD COMBINATION DRIVE
ZINC PLATED MILD STEEL

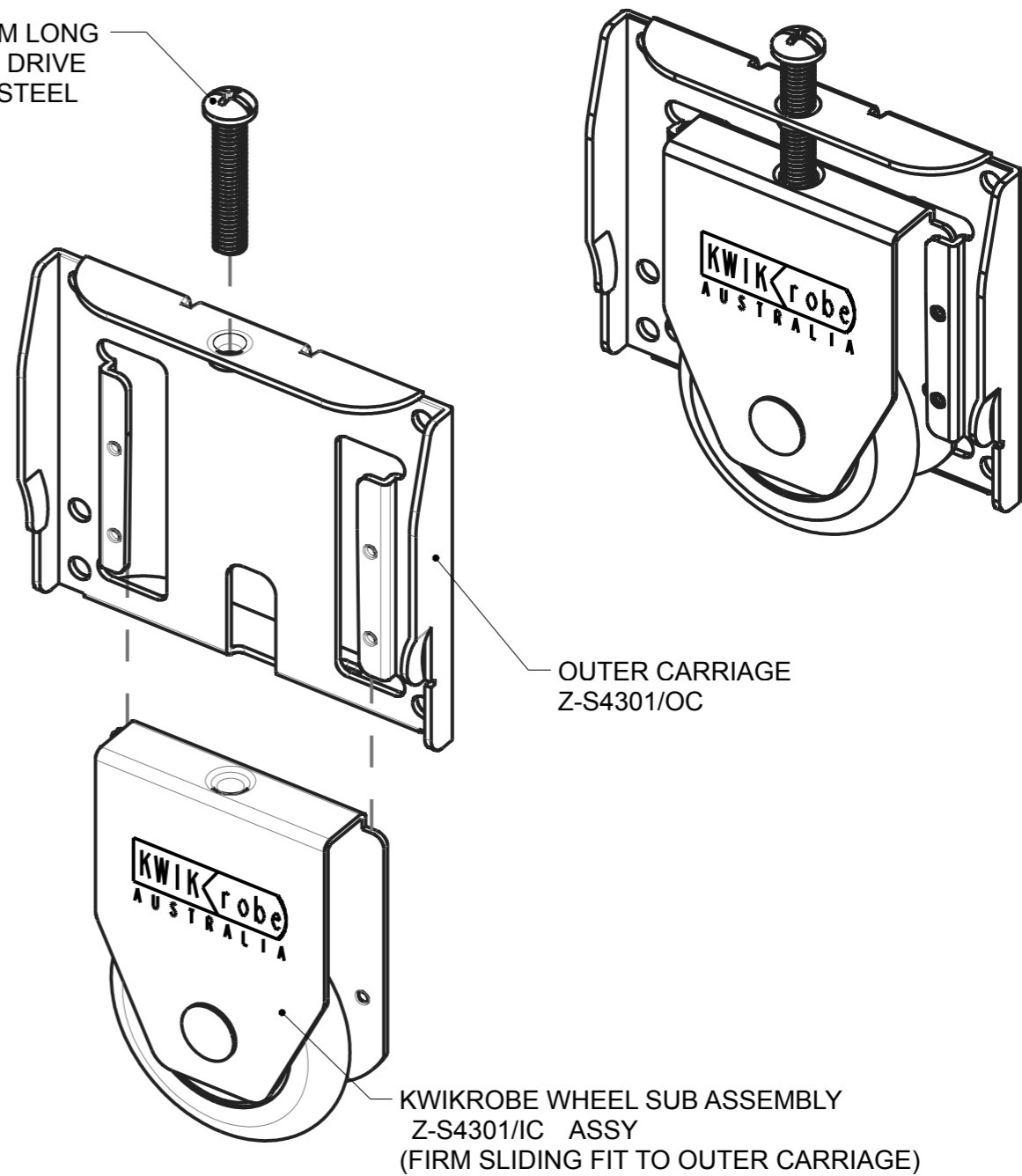

OUTER CARRIAGE
Z-S4301/OC

KWIKROBE WHEEL SUB ASSEMBLY
Z-S4301/IC ASSY
(FIRM SLIDING FIT TO OUTER CARRIAGE)

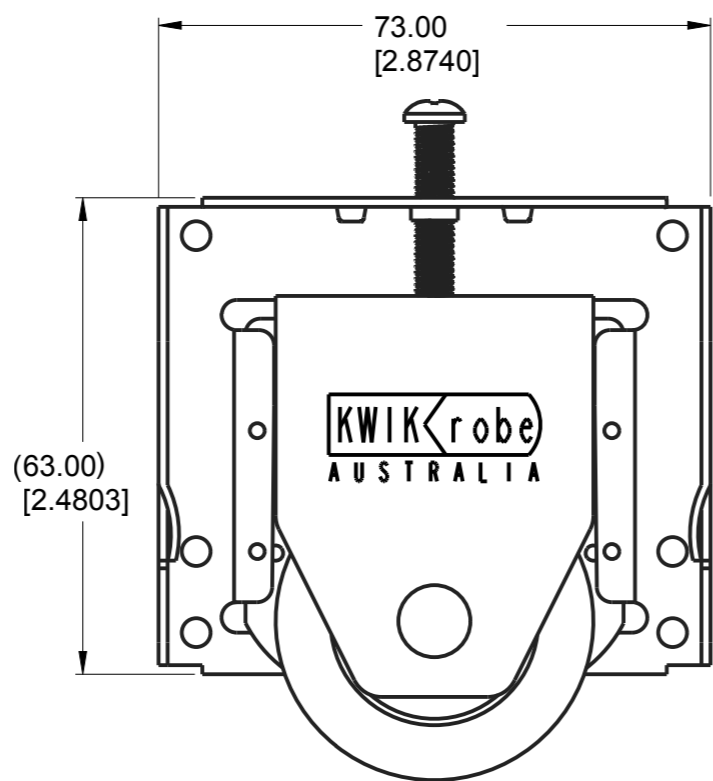
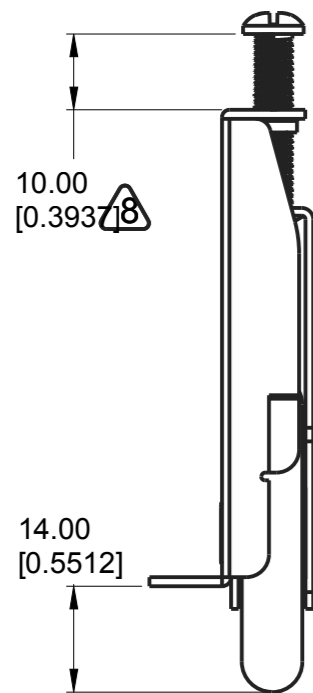

NOTE:
1. LOAD RATING: 30kg MAX.
2. 15mm HEIGHT ADJUSTMENT.

THIS DOCUMENT IS THE PROPERTY OF ANTHONY INNOVATIONS PTY. LTD.
IT IS STRICTLY CONFIDENTIAL AND SUBJECT TO RETURN UPON REQUEST.
IT MUST NOT BE TRACED, COPIED OR EXHIBITED WITHOUT WRITTEN PERMISSION.

3RD ANGLE PROJECTION



Dimensions displayed as: "millimetres [inches]"

DRAWN TO AS1100						DO NOT SCALE		UNSPECIFIED TOLERANCES ± 0.25	
DATE	ECR No.	DRN	CKD	AUTH	REVISION				
TITLE KWIKROBE BEARING ASSEMBLY						DRAWING No.	4488		B1
						ASSEM No.	Z-S4301NA		ZONE
						DRAWING NAME	Z-S4301NA		REVISION
						3D MODEL NAME	Z-S4301NA		8
						DOC No. 19E	COPYRIGHT 2008 - ANTHONY INNOVATIONS ©		A3